

## TE TORX T40 M8

Produzione a disegno.

**Materiali:** 8.8

Possibilità di applicare rondelle impermeabili secondo la DIN 6900.

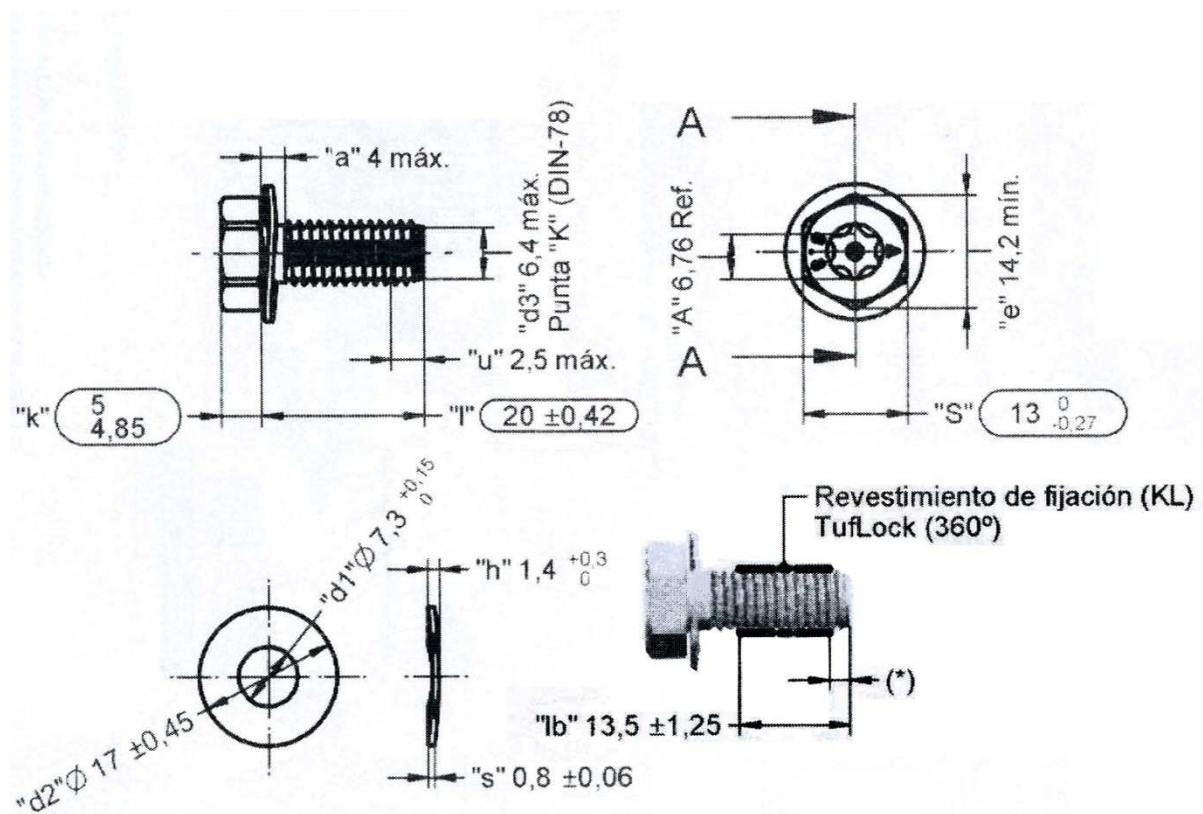



# DIN 6900

Maße in mm

## 1. Schrauben mit eben aufliegenden Köpfen mit Gewinde annähernd bis Kopf

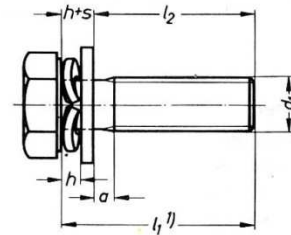
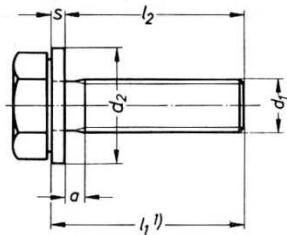

mit Schaft

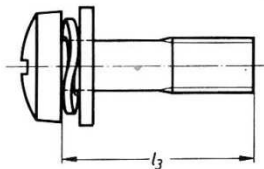
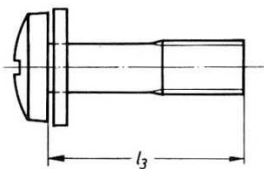

übrige Maße wie Schrauben mit Gewinde annähernd bis Kopf

Tabelle 1.

Gewinde $d_1$	$a$ max.	kleinste nutzbare Schrauben- länge $l_2$ 2)	Mindestlänge bei Schrauben mit Schaft $l_3$		Maße der Unterlegteile													
			Sechskant- schrauben und Innen- sechskant- schrauben	Schlitz- und Kreuz- schlitz- schrauben	Scheibe nach DIN 6902		Feder- scheibe nach DIN 6904		Feder- ring nach DIN 6905		Zahn- scheibe nach DIN 6906		Fächer- scheibe nach DIN 6907		Spann- scheibe nach DIN 6908			
					Form A $s$	Form B $d_2$	$s$	$d_2$	$h$	$d_2$	$h$	$d_2$	$h$	$d_2$	$h$	$d_2$	$h$	$d_2$
M 2,5	0,9	5	16	25	0,6	6,5	0,8	8	—	—	1,1	4,55	0,8	5,5	1,2	5,5	1	6
M 3	1	6	22	25	0,6	7	0,8	9	1,05	8	1,3	5,65	0,8	6	1,2	6	1,2	7
(M 3,5)	1,2	7	25	25	0,8	8	0,8	11	1,15	8	1,3	6,1	1	7	1,5	7	1,2	8
M 4	1,4	8	25	30	0,8	9	1	12	1,65	9	1,4	6,95	1	8	1,5	8	1,5	9
M 5	1,6	10	35	35	1	10	1,6	15	1,75	11	1,7	8,55	1,2	9	1,8	9	1,8	11
M 6	2	12	35	45	1,6	12,5	1,6	18	2	12	2,2	11	1,4	11	2,1	11	2	14
(M 7)	2	14	35	—	1,6	14	2	21	2,4	14	2,2	12	1,6	12,5	2,4	12,5	2,3	17
M 8	2,5	16	40	50	2	17	2	25	2,4	15	2,75	13,95	1,6	14	2,4	14	2,8	18
M 10	3	20	45	55	2,5	21	2,5	30	2,6	21 (18)	3,15	16,95	1,8	18	2,7	18	2,8	23
M 12	3	24	50	—	3	24	3	40	3,2	24	3,65	19,7	2	20,5	3	20,5	3,3	29

