

IVECO 11-0178

Cold-formed steel parts according to norm Iveco 11-0178.

Materials: 5.8 – 8.8 – A2

RAPPRESENTAZIONE E DIMENSIONI

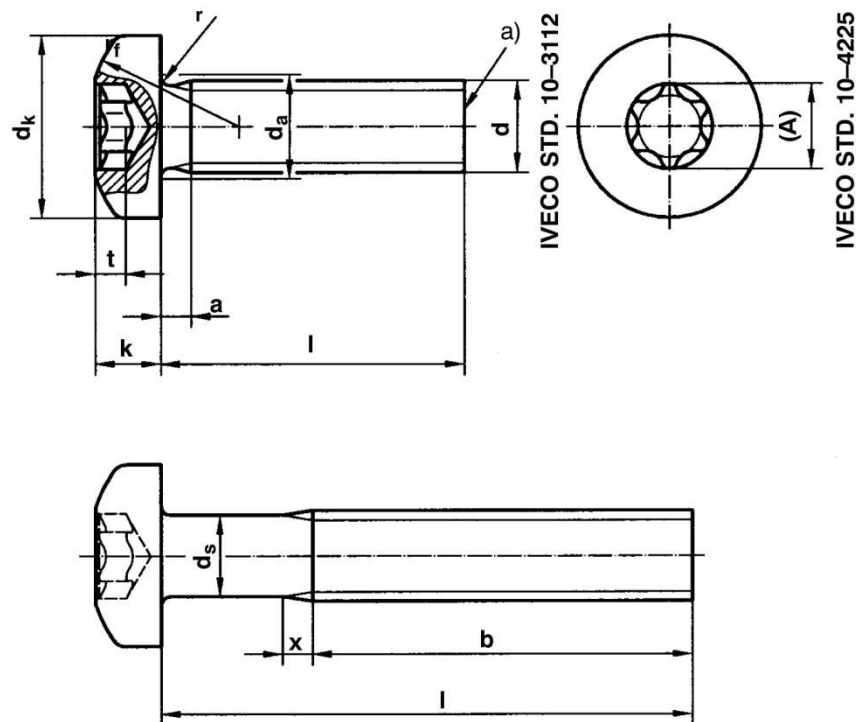

Dimensioni fondamentali

Filettatura d	M3	M4	M5	M6	M8	M10	M12		
Passo P	0.5	0.7	0.8	1.0	1.25	1.5	1.75		
a	max. 1	1.4	1.6	2	2.5	3	—		
b	min. 25	38	38	38	38	38	—		
da	max. 3.6	4.7	5.7	6.8	9.2	11.2	14.2		
dk	nom. = max. 5.6	8.00	9.50	12.00	16.00	20.00	24.00		
	min. 5.3	7.64	9.14	11.57	15.57	19.48	23.48		
k	nom. = max. 2.40	3.10	3.70	4.6	6.0	7.50	9		
	min. 2.26	2.92	3.52	4.3	5.7	7.14	8.6		
r	max. 0.1	0.2	0.2	0.25	0.4	0.4	0.5		
r _f	5	6.5	8	10	13	16	20		
x	max. 1.25	1.75	2.0	2.5	3.2	3.8	—		
Impronta esalobata	Impronta N°	10	20	25	30	45	50	55	
		A	ref	2.8	3.95	4.5	5.6	7.95	8.95
	t	max.	1.27	1.66	1.91	2.42	3.18	4.02	4.15
		min.	1.01	1.27	1.52	2.02	2.79	3.62	3.75

NOTA : a) Estremità rullata

Il diametro del gambo d_s è approssimativamente uguale al diametro medio di filettatura